

SA-36 F series

SS316L fixed analogue camera

- ✓ Corrosion protected 316L stainless steel
- ✓ Low maintenance
- ✓ 550 TVL PAL or NTSC CCD camera
- ✓ 36x optical zoom 12x digital zoom
- ✓ Integrated heater
- ✓ Optional wiper, washer tank and termination box
- ✓ Optional: Direct to Fiber



Description

The SA-BC36 F is a 36x zoom analogue camera built in a fixed camera housing designed for use in onshore, offshore, marine and heavy industrial environments. The camera housing is constructed from electro-polished 316L stainless steel for maximum corrosion protection and is fitted as standard with sunshield and thermostatically controlled heater element. Optionally the camera can be connected direct to optical fiber.

Corrosion free 316L construction

The SA-BC36 housing is suited to be used in salty or sulphur rich environments. 100% of the camera housing is made of corrosion proof 316L steel.

Integrated analogue zoom box camera

Fitted as standard, the SA-BC36 F is equipped with a 36x optical zoom analogue day/ night camera. The 36x zoom realizes the optimum field of view in any situation. The camera is controlled by Pelco D commands over RS485.

Image enhancement

The camera provides automatic day/night functionality for use in low light situations. The WDR brings out details in dark areas and details in the bright areas by combining the best of two exposures.

Washer/Wiper option

The SA-BC36 F-WW version is standard equipped with wiper and prepared for a washer hose and nozzle. A pressurized 10 litre washer tank, including hose and nozzle is sold separately.

Direct to fiber

As an option the camera can be fitted with a optical fiber connection (2SM). The duplex single mode fiber is preconfigured with dual LC connectors.

SA-BC36 F series

SS316L fixed analogue camera

Camera housing

Ingress protection rating	IP66/ IP67
Body material	Electro-polished 316L stainless steel
Sunshield	Standard
Internal demister/heater	Standard
Wiper	Optional (F-WW version only)
Washer system	Optional (EX-WP10 Ex e 24 or EX-WP10 Ex d 24)
Operating temperature	-20 °C to +60 °C
“Dry heat” test	+75 °C, 2 days
Weight	
SA-BC36 F 24 3C	7 kg
SA-BC36 F-WW 24 3C	8 kg

Electrical

Zoom, wiper and washer control	2-wire RS485, Pelco D, 2400 baud
Supply voltage	24 V~ 50/60 Hz; Optional 115 V~ 50/60 Hz; 230 V~ 50/60 Hz
Power consumption	25 W maximum
Electrical connections	Internal termination block

Camera

Image sensor	1/4” Ex-View HAD CCD
Effective pixels	380,000 (NTSC) or 440,000 (PAL)
Shutter speed	1/3 - 1/10000 s
Minimum scene illumination	0.1 lux (colour), 0.01 lux (b/w), F/1.6
Dynamic range (WDR)	90 dB
Lens	36x Optical zoom, F/1.6 (W), F5 (T); 12x digital zoom
Lens focal length	3.4 mm (W) – 122.4 mm (T)
Horizontal field of view	57.8° (W) – 1.7° (T)
Features	WDR, (3D/2D) noise,
Exposure	Auto (iris)
Day/Night (IR-cut filter)	Auto

Video

Component Video	/P version for PAL /N version for NTSC
Resolutions	550 TVL
Video frame rate	/P version: 25 fps /N version: 30 fps
Video output	Internal 75 Ω BNC

Order information

SA-BC36/P F 24	316L fixed analogue, 36x PAL 24Vac
SA-BC36/P F 24 2SM	316L fixed analogue, 36x PAL 24Vac, 2SM
SA-BC36/P F-WW 24	316L fixed wiper analogue, 36x PAL 24Vac
SA-BC36/P F-WW 24 2SM	316L fixed wiper analogue, 36x PAL 24Vac, 2SM
SA-BC36/N F 24	316L fixed analogue, 36x NTSC 24Vac
SA-BC36/N F 24 2SM	316L fixed analogue, 36x NTSC 24Vac, 2SM
SA-BC36/N F-WW 24	316L fixed wiper analogue, 36x NTSC 24Vac
SA-BC36/N F-WW 24 2SM	316L fixed wiper analogue, 36x NTSC 24Vac, 2SM
<i>For 115 Vac or 230 Vac option</i>	<i>Replace 24 with 115 or 230 respectively</i>

SA-BC36 F series

SS316L fixed analogue camera

Accessories

SA pole mounting adapter F



316L pole mounting adapter for SA wall mounting bracket F

SA wall mounting bracket F



316L wall mounting bracket for SA fixed camera housings

SA ceiling mounting bracket F

316L ceiling mounting bracket for SA fixed camera housings

SA Pole Top Mounting F



316L pole top mount with swivel joint for SA fixed camera housings

SA-WP10-10m-VSF-24 v2



10 liters washer tank, pump 10 m delivery head, 316L frame, 24 Vac

Maintenance & replacement kits

EX/SA-MK Wiper

Maintenance kit for the wiper: Rubber blade and support

EX/SA-Wiper

Replacement for Stainless steel wiper (complete assembly)

SA-MK fixed

Maintenance kit SA fixed camera: O-Ring, screws, 2x cable glands, desiccant bags

SA-BC36 F series

SS316L fixed analogue camera

SA-BC36 F series

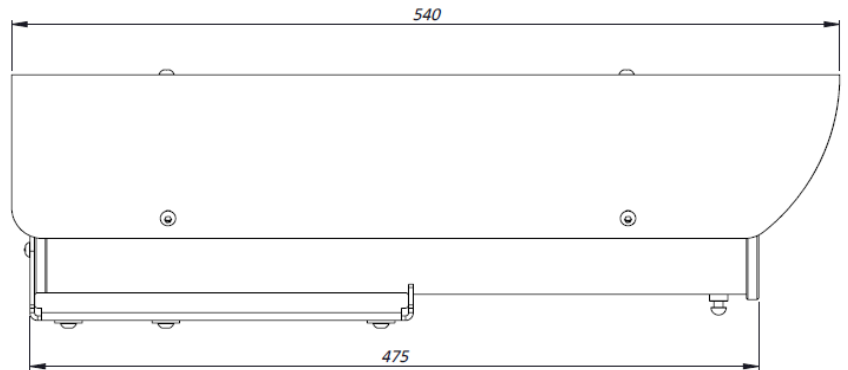
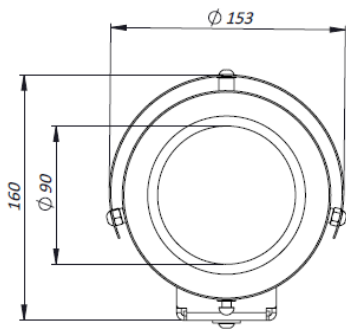

SA-BC63 F-WW series

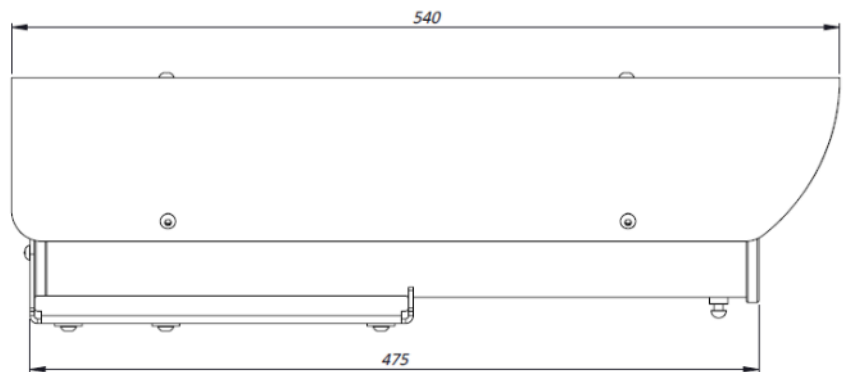
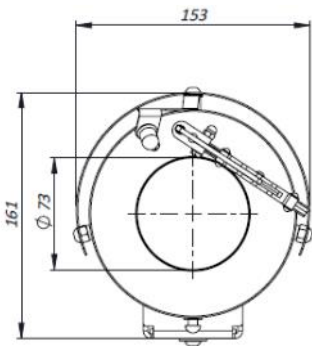

Mounting pattern

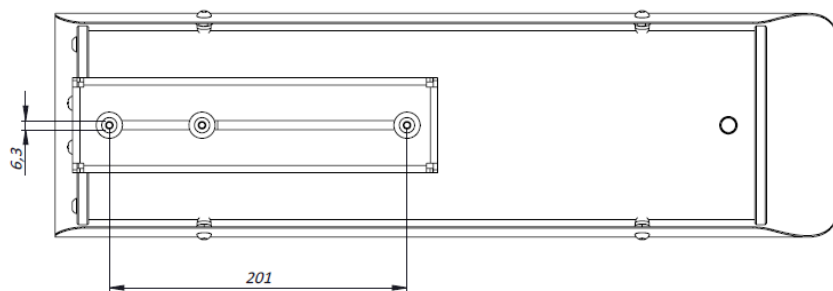

All dimensions in mm



The quality management system used in the development, production, sales, and support of this product is ISO 9001:2008 certified by LRQA.
© Sigura B.V. 2017 - Version 1.0 - Subject to modification.

